

Mesa linear de translação - Série CXS



Exemplo: **CXS12-50AS**
CXS20-100A

C X S		-		
Modelo	Diâmetro (mm)		Curso (mm)	
	6	16	150mm	Ajuste de curso
	8	20		AS Na extremidade final
	12	25		AT Na extremidade inicial
				A Nas duas extremidades

Características Técnicas						
Diâmetro (mm)	6	8	12	16	20	25
Rosca	M3 x 0.5	M5 x 0.8		1/8"		
Fluido	Ar					
Pressão de teste (Bar)	10.5					
Pressão de trabalho (Bar)	1.5 à 7					
Temp. de trabalho (°C)	-10 ~ 60					
Velocidade do êmbolo (mm/s)	50 à 500					
Amortecimento	elástico, hidráulico (opcional)					
Lubrificação	Não necessário					

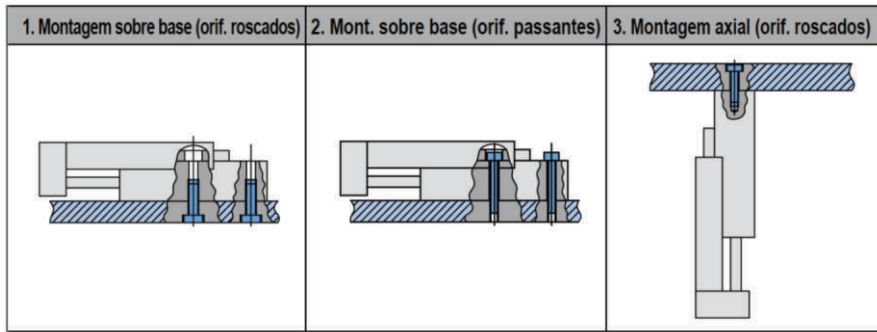

Acessórios



Amortecedor		
Diâmetro (mm)	Rosca	Código
15	M8 x 1.0	AM-0806
20	M10 x 1.0	AM-1008
25	M14 x 1.5	AM-1416
32	M20 x 1.5	AM-2020
40	M20 x 1.5	AM-2020

Sensor Aplicável

SM - 07 - [] - []

Tipo	
R	Reed (2 fios)
P	PNP (3 fios)
N	NPN (3 fios)

Cabo	
M8	Conector M8
2M	2 metros

Exemplo: **SM-07R-2M**
SM-32P-M8

(Unidade: N)

Diâmetro (mm)	Cursos Padrões
6	10, 20, 30, 40, 50.
8	10, 20, 30, 40, 50, 75.
12	10, 20, 30, 40, 50, 75, 100.
16	10, 20, 30, 40, 50, 75, 100, 125.
20	10, 20, 30, 40, 50, 75, 100, 125, 150.
25	10, 20, 30, 40, 50, 75, 100, 125, 150.

Kit Reparo		
Ø do cilindro	Código	Compõe o kit
6	KR-CXS6	Vedação do êmbolo; Vedação da haste.
8	KR-CXS8	
12	KR-CXS12	
16	KR-CXS16	
20	KR-CXS20	
25	KR-CXS25	

Força Teórica									
Diâmetro (mm)	Diâmetro da haste (mm)	Direção do trabalho	Secção do êmbolo (mm²)	Pressão de trabalho (Bar)					
				2	3	4	5	6	7
6	3	Saída	57	11	17	23	29	34	40
		Entrada	42	8	13	17	21	25	29
8	4	Saída	101	20	30	40	51	61	71
		Entrada	75	15	23	30	38	45	53
12	6	Saída	226	45	68	90	113	136	158
		Entrada	170	34	51	68	85	102	119
16	8	Saída	402	80	121	161	201	241	281
		Entrada	302	60	91	121	151	181	211
20	10	Saída	628	126	188	251	314	377	440
		Entrada	471	94	141	188	236	283	330
25	12	Saída	982	196	295	393	491	589	687
		Entrada	756	151	227	302	378	454	529

Nota 1) Força teórica (N) = Pressão (Mpa) x Secção do êmbolo (mm²)
Nota 2) 0.1 Mpa = 1 Bar



Dimensional - Ø6mm (Padrão)

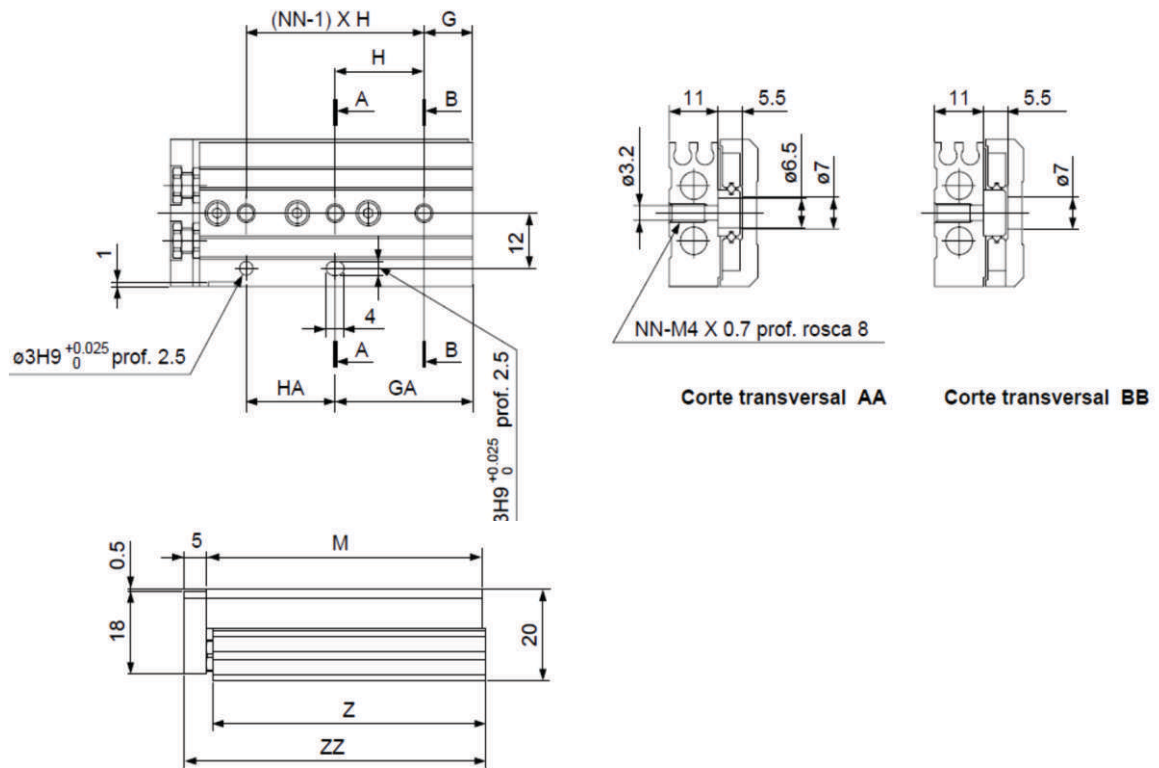

Dimensional - Ø6mm (C/Amortecimento)

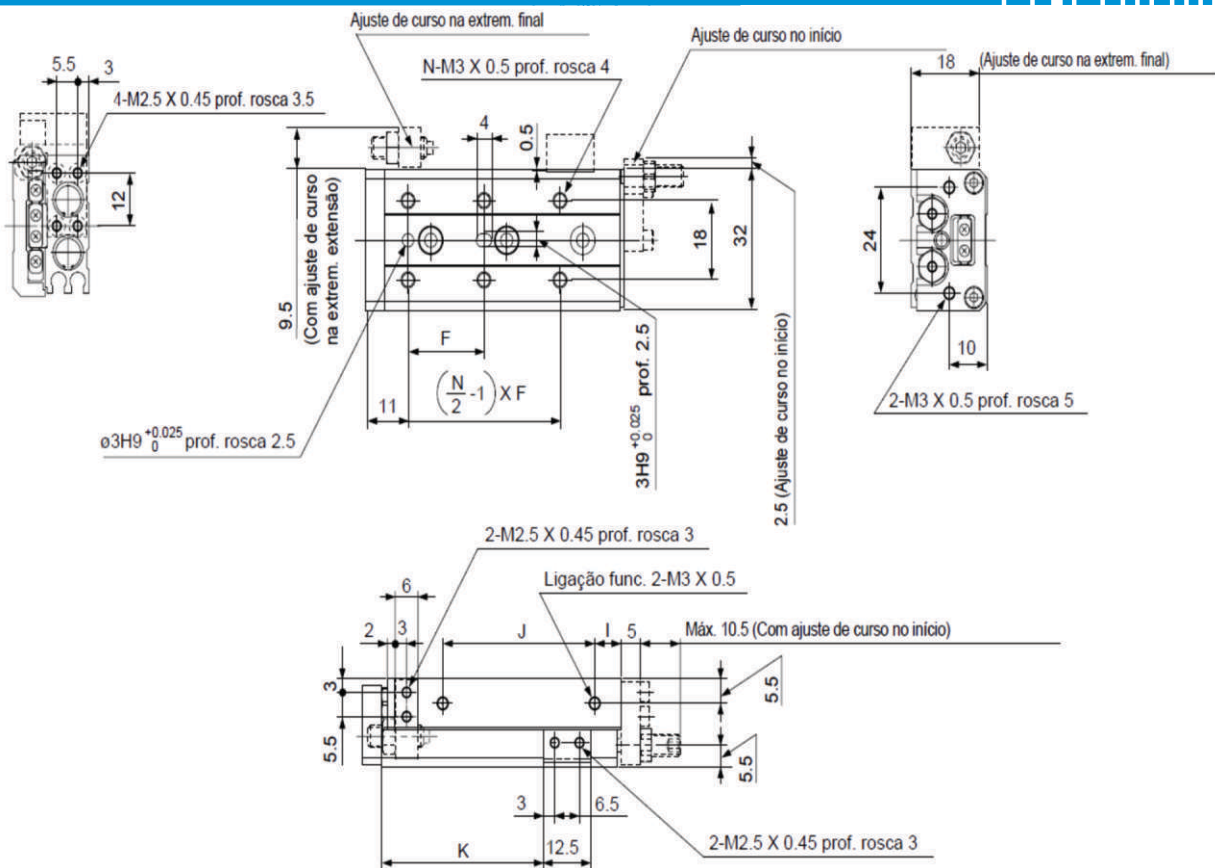

(mm)

Modelo	F	N	G	H	NN	GA	HA	I	J	K	M	Z	ZZ
CXS6-10	20	4	6	25	2	12	25	10	17	26	42	41.5	48
CXS6-20	30	4	6	35	2	12	20	10	27	36	52	51.5	58
CXS6-30	20	6	11	20	3	22	20	7	40	46	62	61.5	68
CXS6-40	28	6	13	30	3	26	30	19	50	56	84	83.5	90
CXS6-50	38	6	17	24	4	34	48	25	60	66	100	99.5	106



Dimensional - Ø12mm (Padrão)

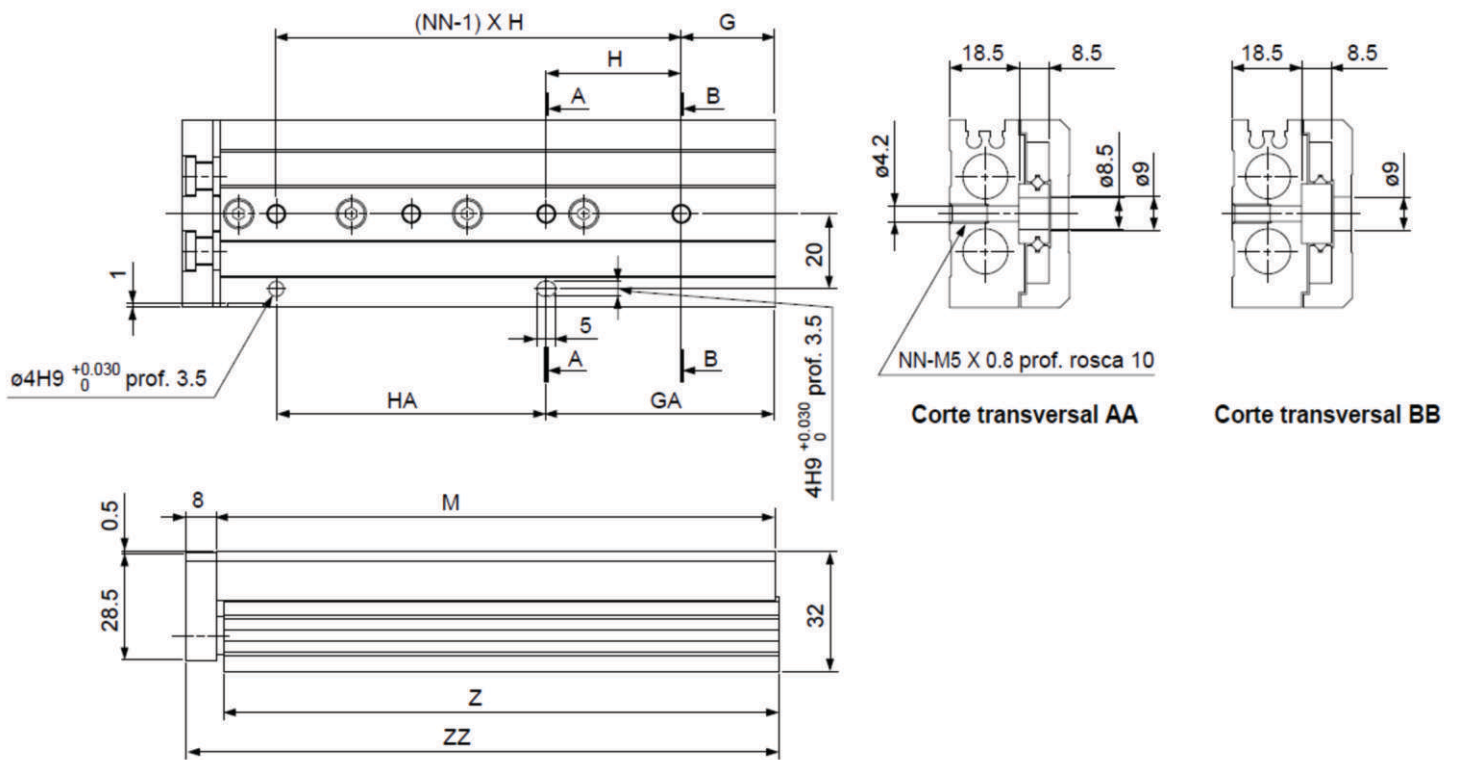

Dimensional - Ø12mm (C/Amortecimento)

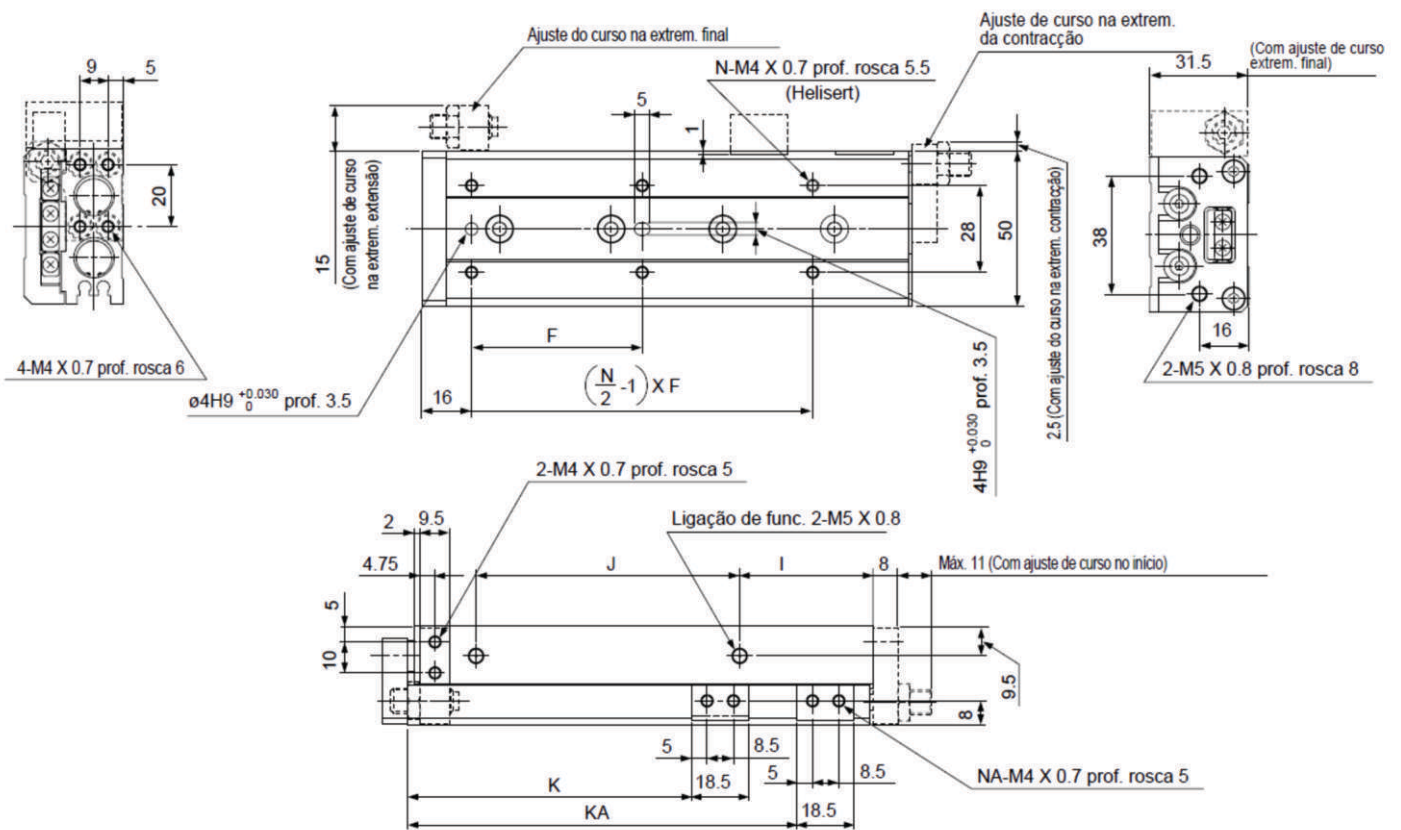

Modelo	F	N	G	H	NN	GA	HA	I	J	K	KA	NA	M	Z	ZZ
CXS12-10	35	4	15	40	2	15	40	10	40	26.5	-	4	71	70	80
CXS12-20	35	4	15	40	2	15	40	10	40	36.5	-	4	71	70	80
CXS12-30	35	4	15	40	2	15	40	10	40	46.5	-	4	71	70	80
CXS12-40	50	4	17	25	3	42	25	10	52	56.5	-	4	83	82	92
CXS12-50	35	6	15	36	3	51	36	22	60	66.5	-	4	103	102	112
CXS12-75	55	6	25	36	4	61	72	43	85	91.5	125.5	8	149	148	158
CXS12-100	65	6	35	38	5	111	76	52	130	116.5	179.5	8	203	202	212

(mm)



Dimensional - Ø16mm (Padrão)

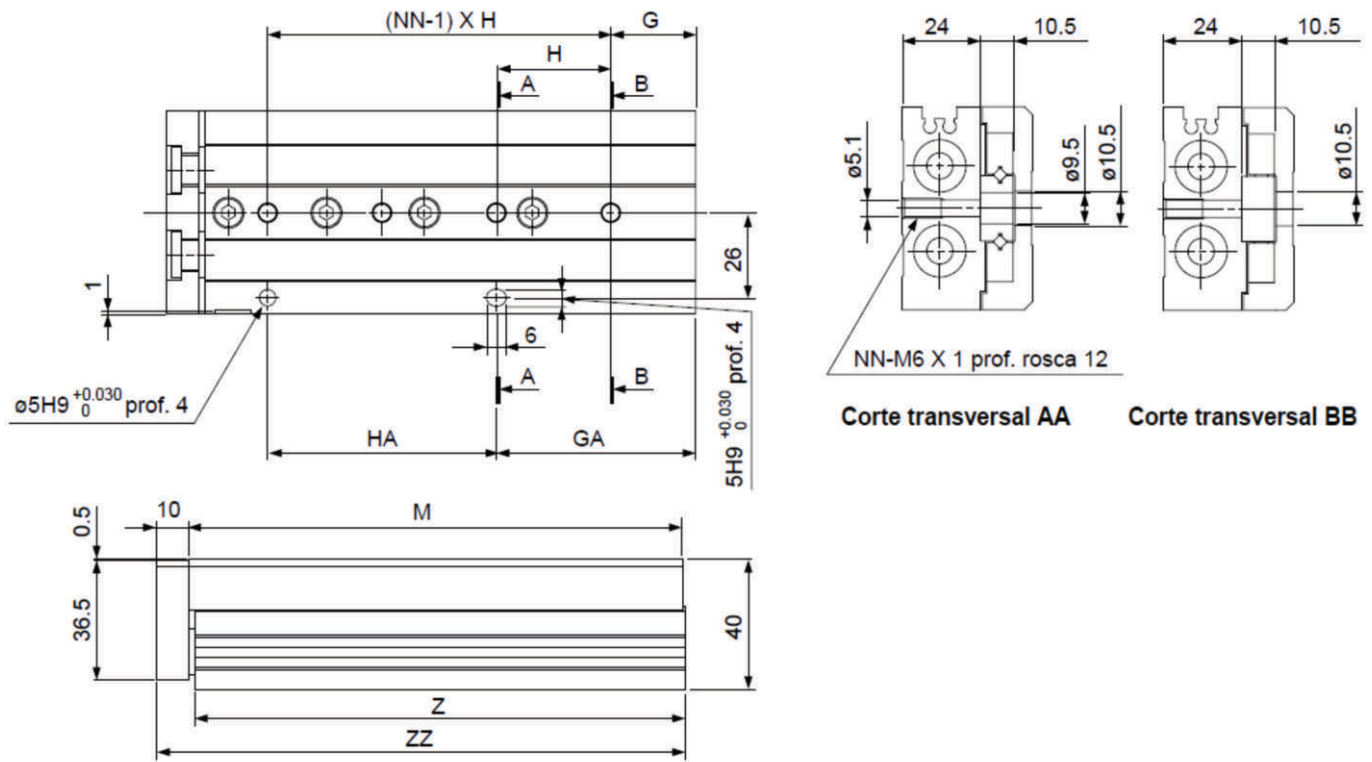

Dimensional - Ø16mm (C/Amortecimento)

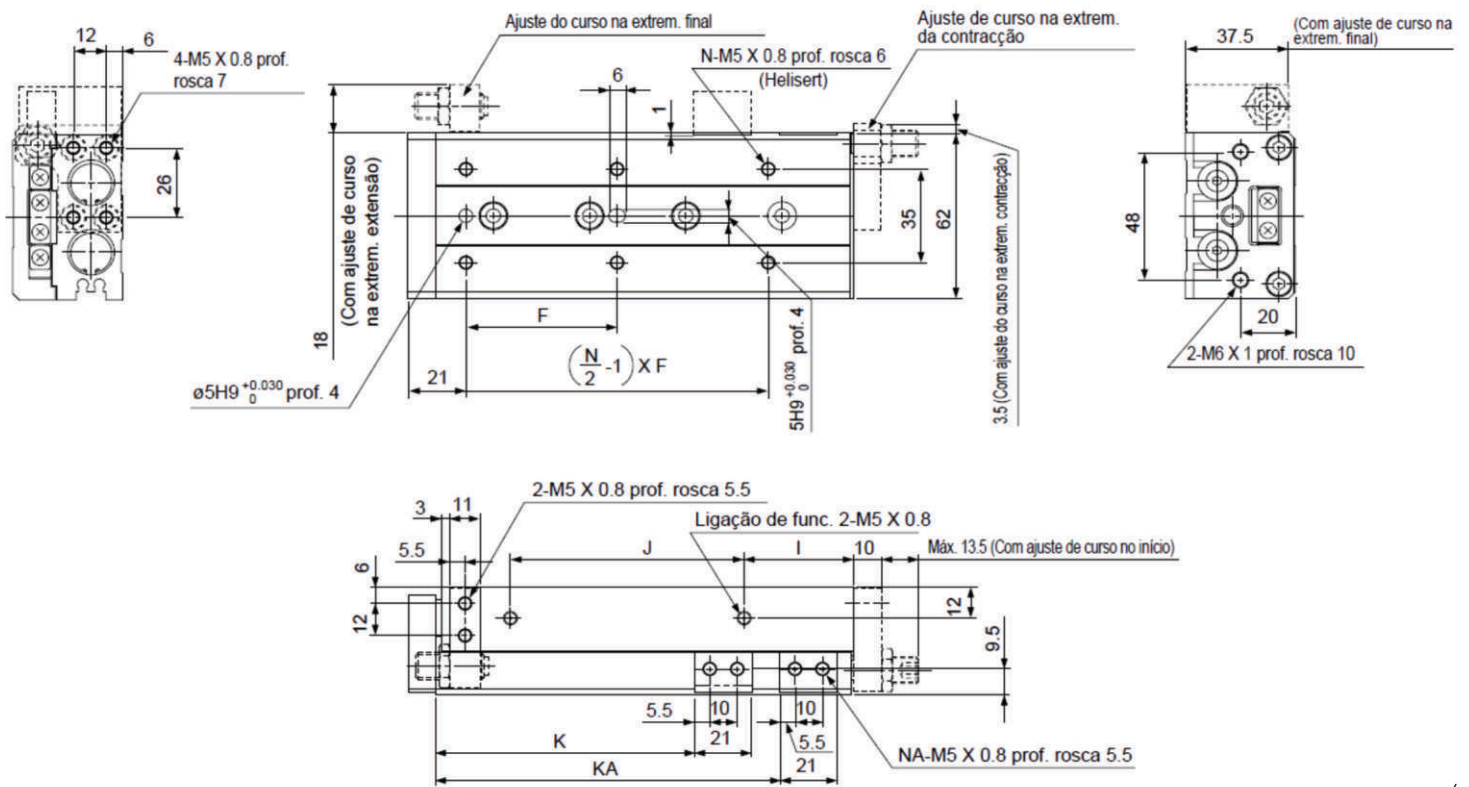

(mm)

Modelo	F	N	G	H	NN	GA	HA	I	J	K	KA	NA	M	Z	ZZ
CXS16-10	35	4	16	40	2	16	40	10	40	29	-	4	76	75	87
CXS16-20	35	4	16	40	2	16	40	10	40	39	-	4	76	75	87
CXS16-30	35	4	16	40	2	16	40	10	40	49	-	4	76	75	87
CXS16-40	40	4	16	50	2	16	50	10	50	59	-	4	86	85	97
CXS16-50	30	6	21	30	3	51	30	15	60	69	-	4	101	100	112
CXS16-75	55	6	26	35	4	61	70	40	85	94	125	8	151	150	162
CXS16-100	65	6	39	35	5	109	70	55	118	119	173	8	199	198	210
CXS16-125	70	8	19	35	7	159	70	68	155	144	223	8	249	248	260



Dimensional - Ø20mm (Padrão)

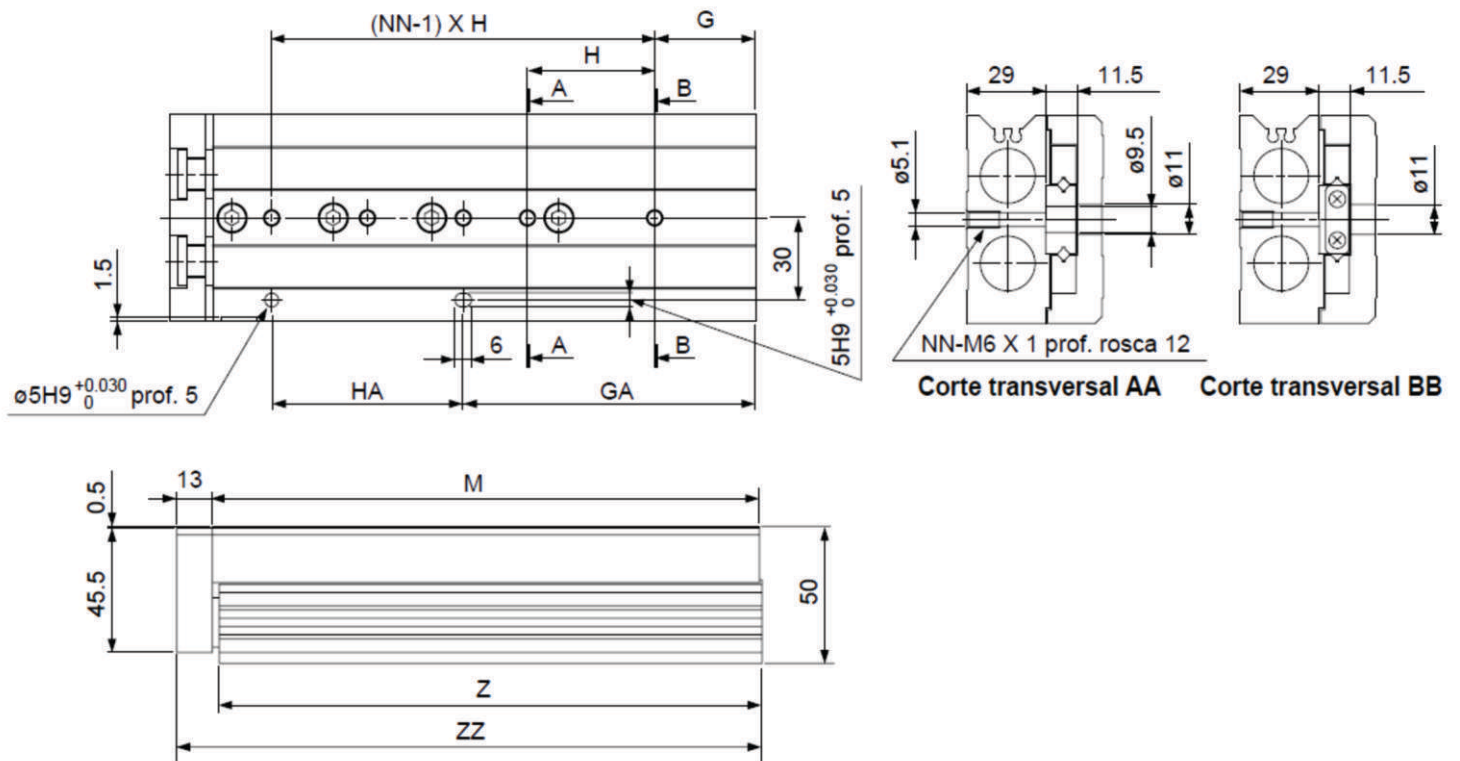

Dimensional - Ø20mm (C/Amortecimento)

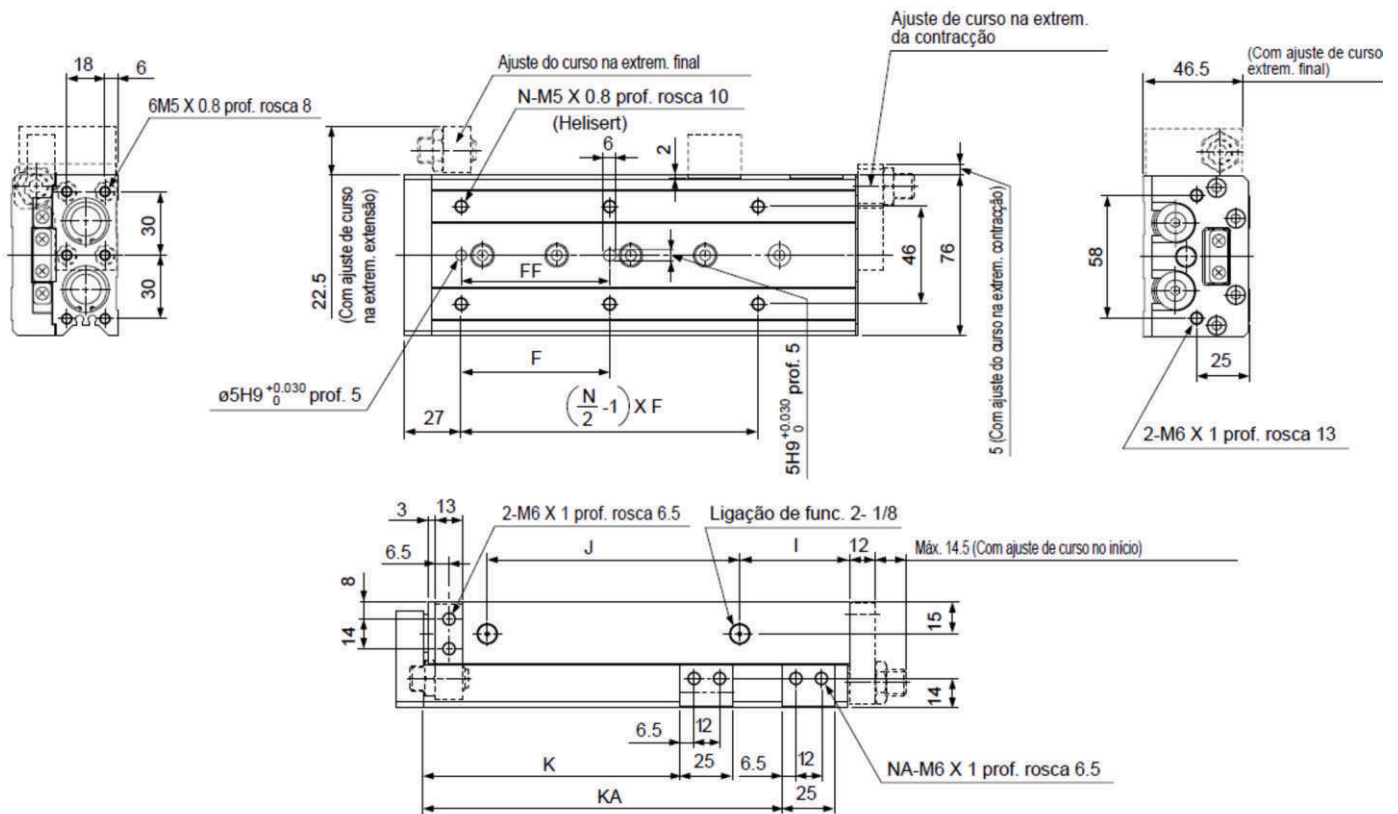

Modelo	F	FF	N	G	H	NN	GA	HA	I	J	K	KA	NA	M	Z	ZZ
CXS20-10	50	40	4	15	45	2	25	35	10	44	31	-	4	83	81.5	97
CXS20-20	50	40	4	15	45	2	25	35	10	44	41	-	4	83	81.5	97
CXS20-30	50	40	4	15	45	2	25	35	10	44	51	-	4	83	81.5	97
CXS20-40	60	50	4	15	55	2	35	35	10	54	61	-	4	93	91.5	107
CXS20-50	35	35	6	15	35	3	50	35	10	69	71	-	4	108	106.5	122
CXS20-75	60	60	6	19	35	4	54	70	10	108	96	-	4	147	145.5	161
CXS20-100	70	70	6	37	35	5	107	70	58	113	121	169	8	200	198.5	214
CXS20-125	70	70	8	41	38	6	155	76	70	155	146	223	8	254	252.5	268
CXS20-150	80	80	8	19	44	7	195	88	87	190	171	275	8	306	304.5	320

(mm)

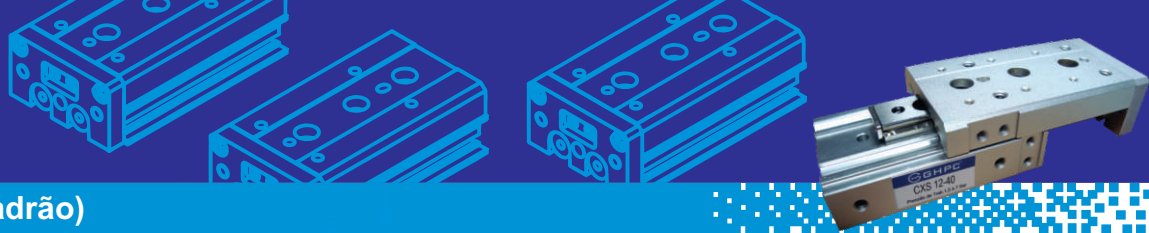

Dimensional - Ø25mm (Padrão)

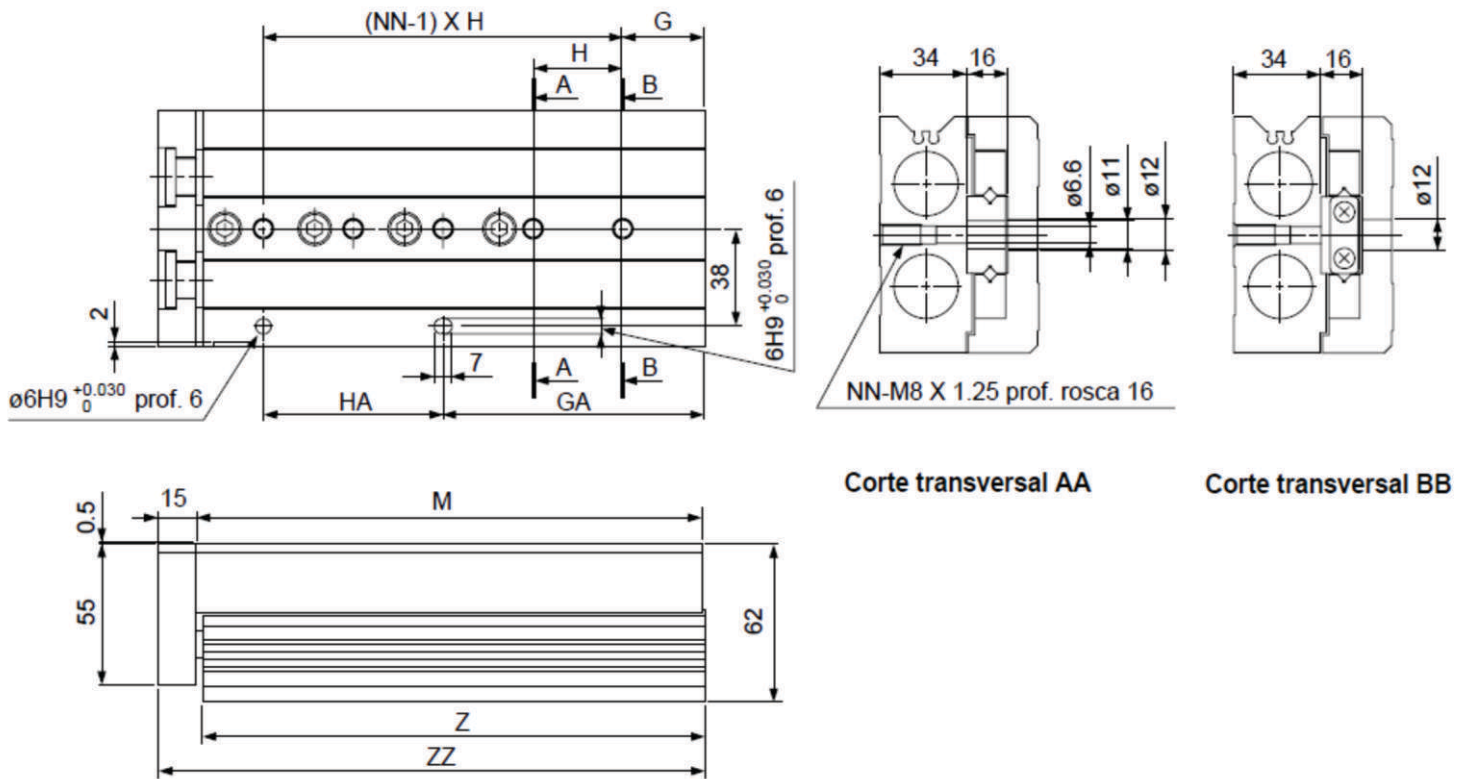

Dimensional - Ø25mm (C/Amortecimento)

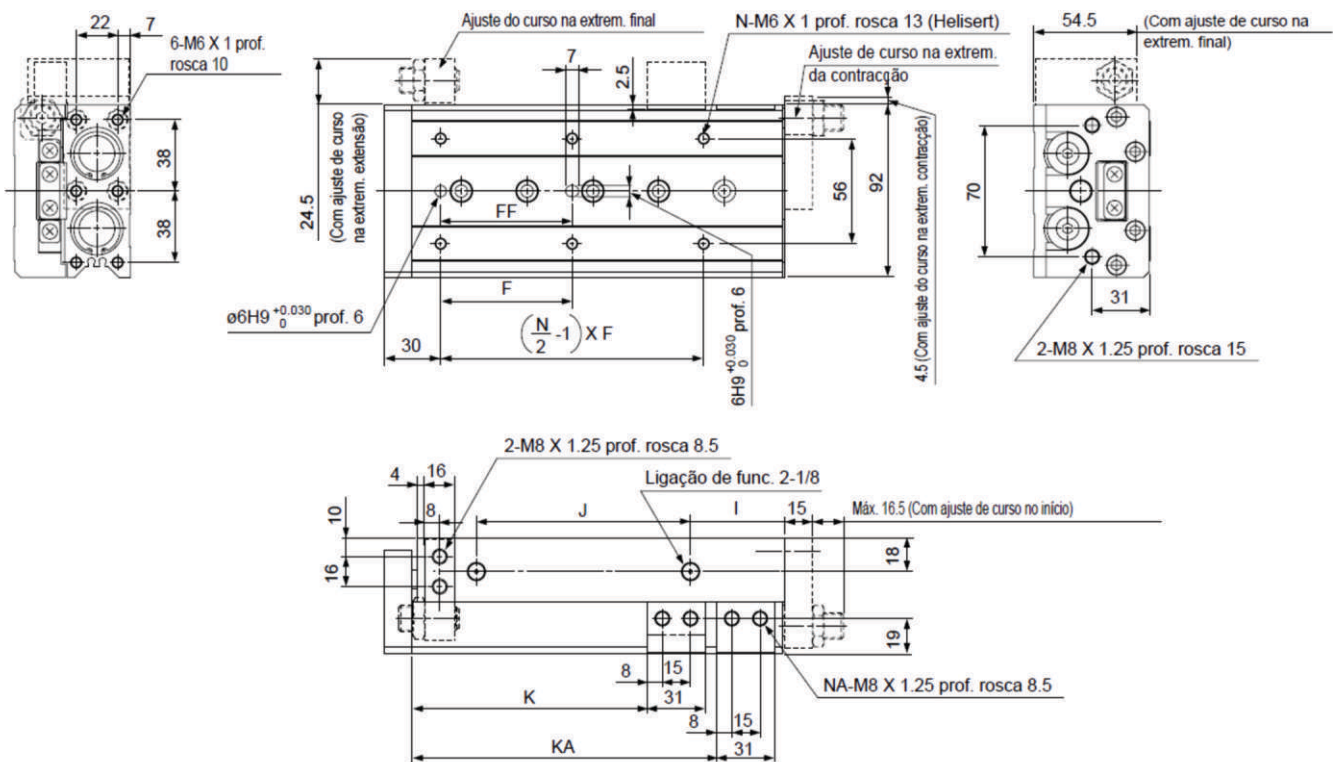

(mm)

Modelo	F	FF	N	G	H	NN	GA	HA	I	J	K	KA	NA	M	Z	ZZ
CXS25-10	50	40	4	22	45	2	22	45	12	47	35	-	4	92	90.5	108.5
CXS25-20	50	40	4	22	45	2	22	45	12	47	45	-	4	92	90.5	108.5
CXS25-30	50	40	4	22	45	2	22	45	12	47	55	-	4	92	90.5	108.5
CXS25-40	60	50	4	22	55	2	22	55	12	57	65	-	4	102	100.5	118.5
CXS25-50	35	35	6	20	35	3	55	35	12	70	75	-	4	115	113.5	131.5
CXS25-75	60	60	6	26	35	4	61	70	33	90	100	-	4	156	154.5	172.5
CXS25-100	70	70	6	32	35	5	102	70	50	114	125	162	8	197	195.5	213.5
CXS25-125	75	75	8	40	38	6	154	76	67	155	150	218	8	255	253.5	271.5
CXS25-150	80	80	8	30	40	7	190	80	82	180	175	258	8	295	293.5	311.5