

VHN 110 – 12P

Feature

- Double-acting pneumatic cylinder
- Variable needle stroke
- Easy Maintenance and needle change
- Easy operation
- Safe handling of the work pieces



Application

- Handling of flexible, non-rigid components
- Handling of material which are difficult to grip with vacuum such as;
 - textiles
 - metal foam
 - fleece
 - insulating mats
 - felt
 - foam materials
 - carpets

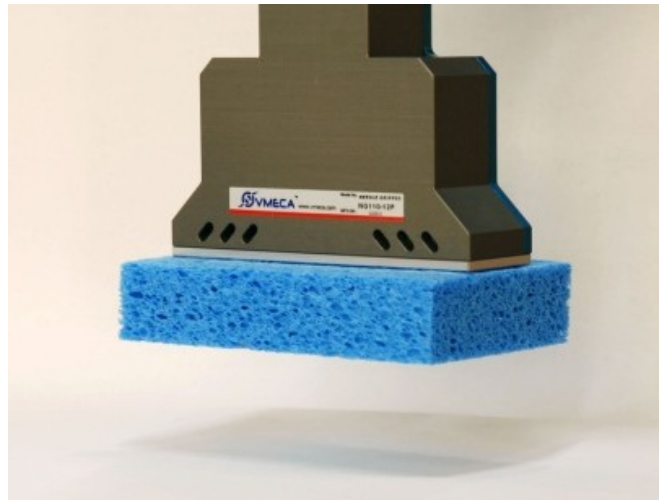

Structure

- Durable aluminum body
- 12 needles
- Needle's angle 45°

Specification

Number of needles	12
Needle diameter [Φ]	0.7
Stroke [mm]	0~3,5
Operating pressure [bar]	3~6
Operating temperature [°C]	5~60
Weight [g]	500.0
Material of Needles	S45C

Adjust the needle's length

Turning the adjust-screw to adjust the length of needle. (0~3.5mm)

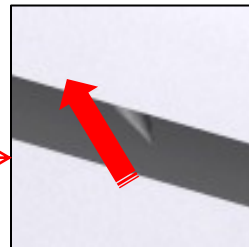
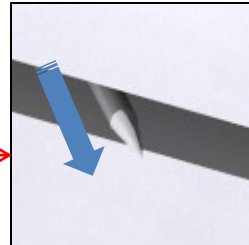

Easy Interchangeable Needles

the needles can be replaced with new one without disassemble the needle gripper.

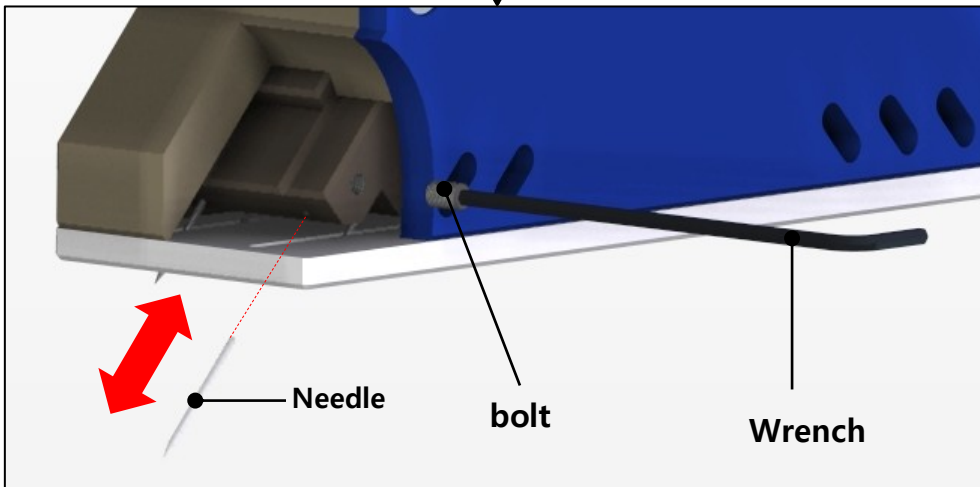
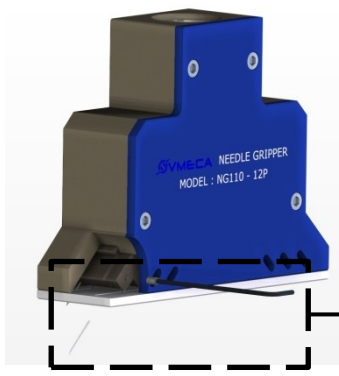

Dimensional Information

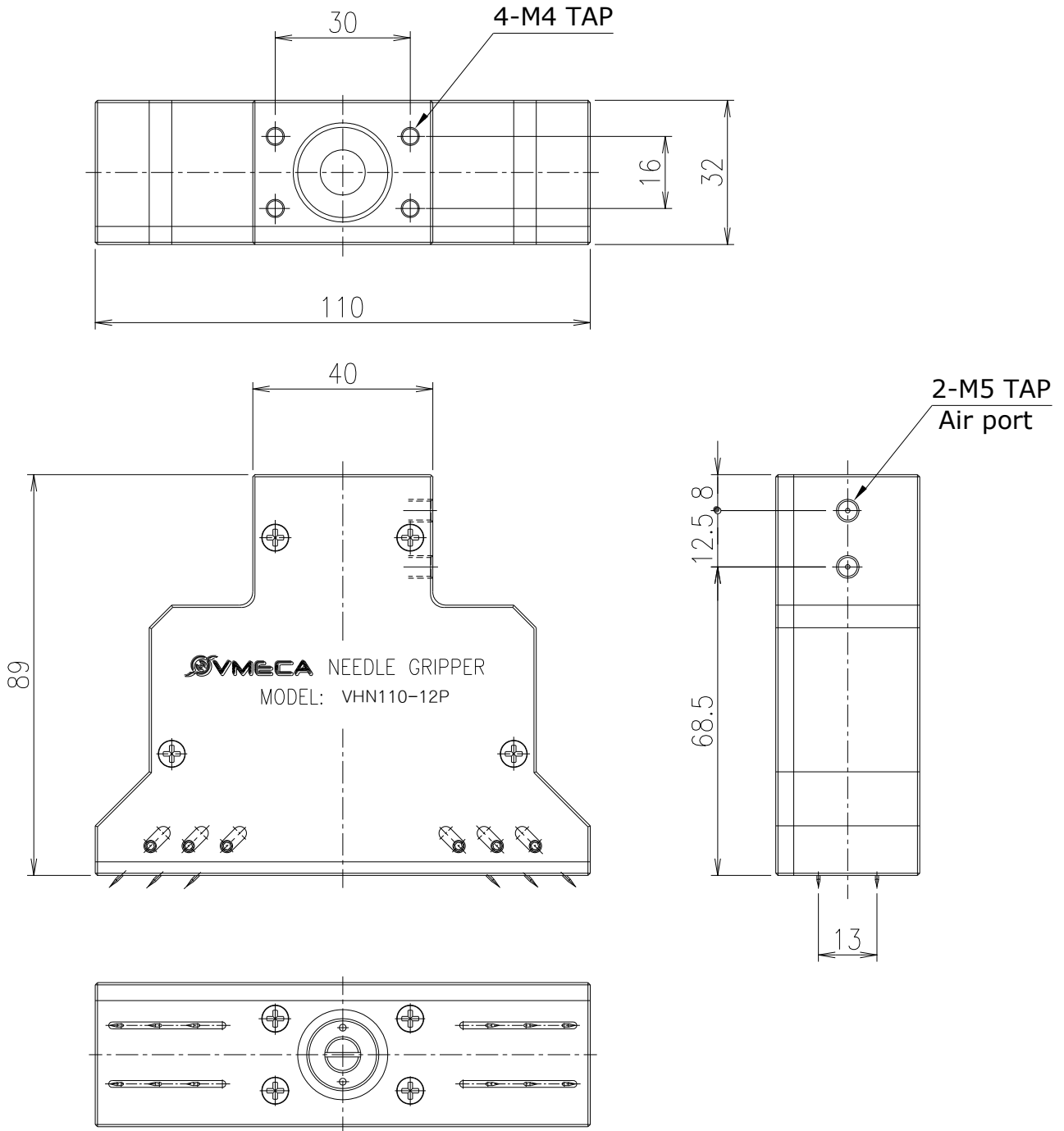

Measure unit : mm